



REPUBLIC OF TURKIYE
MINISTRY OF NATIONAL EDUCATION
The General Directorate
of Technical and Vocational Education

15th INTERNATIONAL MoNE ROBOT CONTEST

MINI SUMO ROBOT CATEGORIES THE RULES

INTERNATIONAL
MoNE
ROBOT
CONTEST

MINI SUMO ONLINE COMPETITION RULES

Access to competition

The Virtual Robot Competition will be held on the Riders Platform. The competitors of the robots registered in the competition will be able to access the competition at <https://riders.ai>.

In order for the competitors to access the competitions, they must come to the Riders Platform via robot.meb.gov.tr via a link belonging to the relevant category on robot.meb.gov.tr. This link will be provided to the competitors by MEB.

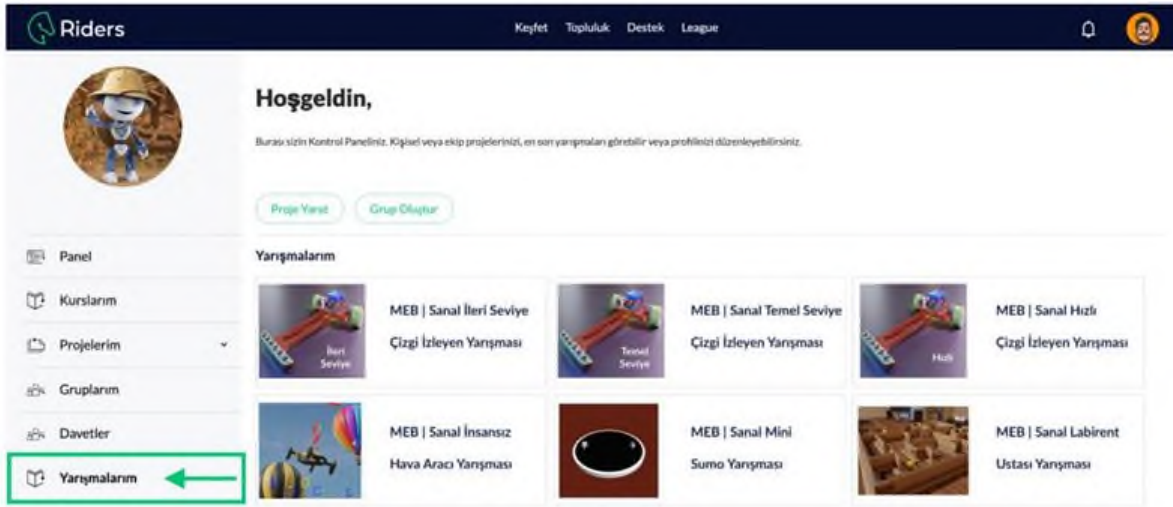

Competitors who come through this link will be able to view the competitions they are registered in the "My Competitions" section on the left side. The competitor will access the competition page by clicking on the competition they are registered for.

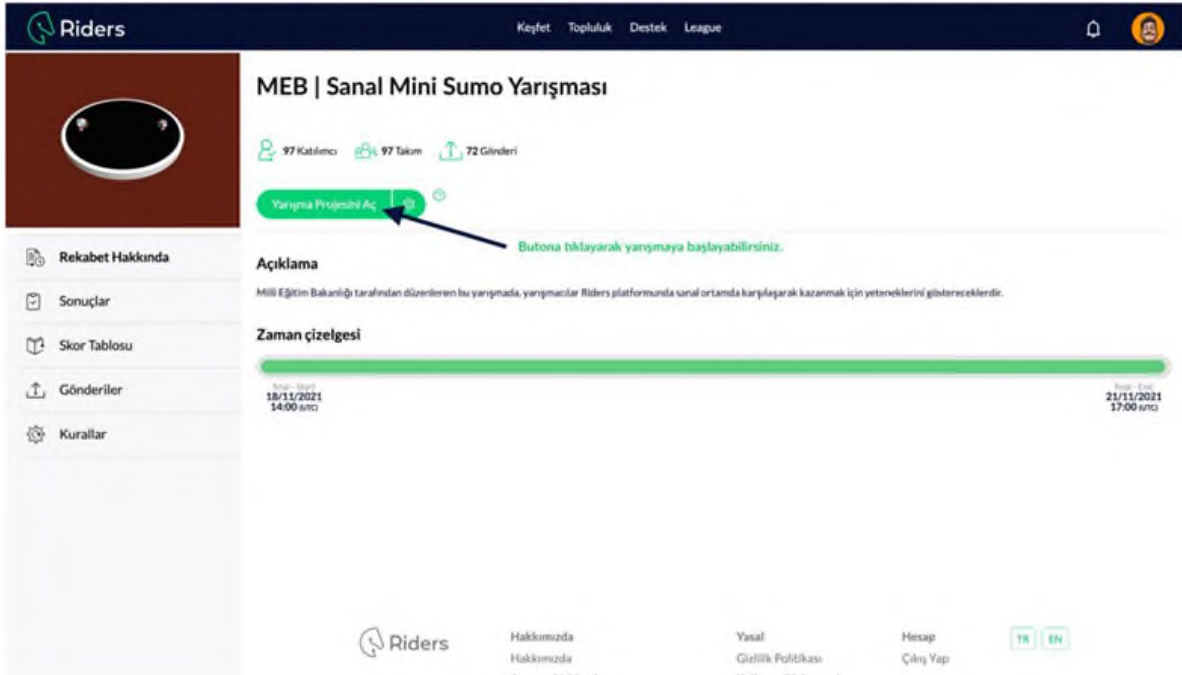

The competitor will open the competition project by clicking the "Open Competition Project" button here.

	Takım Adı	Üyeler	Skor	Kayıtlar	Eksen
1	Robot 1		1.4485	24	2m
2	Robot 2		1.4393	62	2m
3	Robot 3		1.4024	45	2m
4	Robot 4		1.3876	36	2m
5	Robot 5		1.34	69	2m
6	Robot 6		1.2454	68	2m
7	Robot 7		1.1332	9	2m
8	Robot 8		1.0858	12	2m

The competitor will be able to follow the live scoreboard of the competition by clicking on the "Scoreboard" button on the left side

Robot Komutları

Bunlar ihtiyacınız olacak robot komutlarıdır. Ayrıca yeni fonksiyonlar da oluşturabilirsiniz.

- `robot.is_ok()` - Simülasyon çalışırken "True"
- `robot.move(v)` - Robotun hızını ayarlayın. Artı ve eksi değerler belirleyebilirsiniz. v [meter/sec].
- `robot.rotate(ω)` - Robot açısal hızını ayarlayın ω [radian/sec]. Pozitif ω is eSaat yönünün tersidir (CCW). Negatif ω saat yönüdür (CW).
- `robot.get_sensor_data()` - 2D Kamera görüntüsünün piksellerini okumak için kullanılır. Eğer 2 Boyutlu bir görüntü ile çalışmak istiyorsanız bu fonksiyonu kullanabilirsiniz.

Robotunuzun bir kamerası vardır. Simülasyon çalışırken video kamera (video camera) düğmesine tıklayın:

Akan kamera görüntüsünü göreceksiniz.

NOTICE: It is sample. Contents may vary according to competition and robot

In the competition project, there is a "Competition" menu on the left side. Through this menu, the competitor will be able to access the programming code of the robot.

The competition starts by pressing the "Start" button. After a certain period of time after pressing the "Start" button, the "Simulation Screen" will be opened.

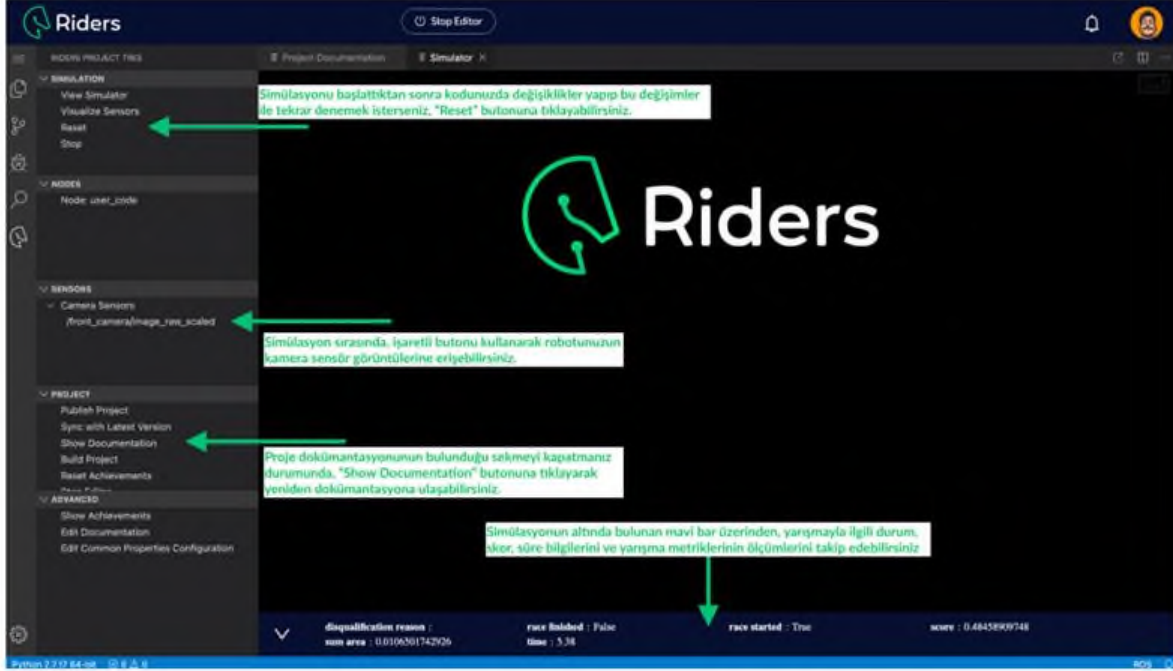

At the bottom of the simulation screen, the elapsed time and the score received by the robot will be displayed. The score of the robot will be made according to the scoring calculation specified in the document.

After improving the robot code, the competitor will be able to restart the competition by pressing the "Reset" button. The competitor has unlimited trial rights at this point until the end date of the "Virtual Mini Sumo Competition".

In the Virtual Mini Sumo Competition, the highest of the points received by the competitors in the robot's team will be the robot's score.

Definition od Competition

A competition will consist of 10 rounds. In each round, the robot will race an AI-controlled virtual robot assigned by the simulation system. The robot's task is to throw the AI-controlled rival robot out of the dohyo as soon as possible. The winner of each round is announced by the platform. If the robot throws the AI-controlled rival robot out in any round, it will receive a point depending on the throwing time, as well as an additional bonus point. Detailed information about the bonus points will be explained in the "Mini Sumo competition project document". If the robot is not the winner of the competition in any round, the score from that round will be zero. The average of the points obtained from the 10 rounds in total will be the score of the robot from that competition.

Dohyo Specifications

Competition Ring Area

- In the virtual competition, the Mini Sumo Robot dohyos are set to be 5cm high from the ground and 77cm in diameter.



- The separation line of the Mini Sumo Robot dohyos is the 2.5cm white area on the edge. The white area is within the dohyo. The floor of the dohyo is black.

Robot Specification

Robot Definition

Within the framework of the Virtual Mini Sumo Competition, a robot will be given to the competitors. This robot will have distance sensors and colour sensors that detect the colour of the floor. The given robot has motorised wheels. Information on how the competitor can control these motors and receive data from the sensors will be included in the "Virtual Robot Competition Training" and "Competition Project Document". The description of the robot is as follows:

1. Robot control
 - a. Robots will be autonomous.
2. Starting movement
 - a. When you press "start" button on the simulation platform, competition and first round will start. Robots will run according to their algorithm.
 - b. When you press "Reset" button on the simulation platform, competition will start again
3. Finishing movement
 - a. Round will end by the simulation system. If competition is stopped by competitor in any way (closing the simulation, pressing "reset" or "stop" buttons,) the competition is also terminated. In such a case, the points obtained in the current competition will not be saved and will be deleted.

Robot movements

Robot movements should be designed as detect the opponent's movements and respond/attack

Game rules

1. Game is 3 minutes and 10 rounds. Competition will start again when you press on "start" button or each press on "reset" button.
2. Competitors can make practice as many as they wish until the deadline of Virtual Mini Sumo Competition
3. Opponent assigned by simulation system will be AI- controlled robot
4. In a 4.3 minute round, the robot that can take the AI-controlled robot out of the dohyo in the shortest time will get a point depending on the time and in addition to this, it will get a bonus point for winning the round. The size of this bonus point and how it is calculated will be explained in detail in the "Mini Sumo Robot Competition Document".
5. If the robot is not the winner of a round, the score from that round will be zero.
6. The competition score will be obtained by averaging the scores obtained from 10 rounds.
7. If the score obtained by the robot as a result of the competition is greater than the highest score of the robot so far, the score obtained will be recorded in the score table.
8. The programming language shown in the Virtual Robot Competition training will be used in the competition.



9. The dimensions of the robot in the competition will be adjustable so that the width and length dimensions do not exceed 10 cm. The robot height will not exceed 20 cm and will be adjustable. The weight of the robot will increase with the increase in the width and height of the robot. Robot widths will not exceed these limit values.
10. There will be distance sensors on the front, right, left and back of the robot. How to read data from these sensors will be specified in the competition project document.
11. There will be sensors that distinguish black and white in the 4 corners of the bottom of the robot. How to read data from these sensors will be specified in the "Competition Project Document".

Conducting The Competition

Start and Finish of the Competition

1. In the virtual competition, the competitor will open the competition project by following the instructions in the "Access to Virtual Robot Competition" article. When the competition project is opened, the competition and the first round will start and the robot will be automatically placed at the starting point of the competition by the simulation.
2. The competitor will access the code section to develop the robot's algorithm as described in the "Access to Virtual Robot Competition" article. In this code section, the competitor will develop the algorithm.
3. The competitor will click on the "Reset" button in the competition project to load the code developed as described in the "Access to Virtual Robot Competition" article to the robot. Each time the "Reset" button is clicked, the developed code will be loaded to the robot, the robot will be brought to the starting position again, the competition will be restarted and the first round will be opened. Competitors have the right to repeat the above process an unlimited number of times until the end date of the "Virtual Mini Sumo Competition".
4. Robots will be placed in a random position by the simulation system in each round will be started.
5. The first round will be completed if any robot leaves the track or the 3-minute round will be completed at the end of the round.
6. As a result of the completion of the first round, the simulation system will place the robots again with a random positioning for the second round.
7. The rounds after the first round, will be completed if any of robots leaving the track or the end of the 3-minute round time as it is same with first round.
8. Game will be ended when 10 rounds are finished .

Restarting a Competition

1. When competitors click on the "Reset" button in the simulation environment game is restarted from the first round.
2. If the competitor presses the "Reset" button before completing 10 rounds and thus the competition, if there is a score obtained from the rounds up to that point, this score will not be recorded. The condition for receiving points from the competition is to complete all 10 rounds. Scores

Scores

The competitor robot becomes the winner of the round as a result of the following conditions:



1. Within the maximum time (3 minutes), if the artificial intelligence-controlled opponent robot is forced out of the dohyon and is able to contact the outside of the dohyo
2. If the artificial intelligence controlled opponent robot falls out of the dohion or touches the outside of the dohion within the maximum time (3 minutes)

If the competitor robot is not the winner of any round, it will receive zero points from the relevant round. In 10 rounds, the average of the points obtained as a result of the above situations will be the score of the robot from the competition.

The Rules of Mini Sumo Robot Category

Chapter1

General Rules

(Objective)

Article 1: This document defines the rules and regulations of Mini Sumo Robot Tournament.

Chapter 2 Definition of a match

(Definition)

Article 2: For each robot, a single operator and an assistant can be registered. However, only one competitor will operate the robot in match area. Both contestants have to know the competition rules and obey these rules. Robots must be autonomous robots. The winner will be determined by the judges after the match.

Chapter 3.Specifications of Dohyo

(The Match Ring Area)

Article 3: Definition of Dohyo

1. Dohyo consist of the match ring and the outer layer area of the ring. The rest of the space will be deemed as area which is outside of Dohyo and objections for this area won't be accepted.
2. The specification of Dohyo
 - Dohyo of Mini Sumo Robot is a circular MDF board which has 5cm height and 77 cm diameter
3. The dividing line
 - It is the 2,5cm white area outside of Dohyo of Mini Sumo Robot and it is included to dohyo area.



Chapter 4

Specifications of Robot

(The specifications of robot)

Article 4: The specification of robot are as follows.

1. Detailed description of Robot

- Mini Sumo Robot should be 10cm width and 10cm depth (no restriction on the height) and able to be stored **in a cubic box** for inspection purpose.

2. Controlling Robot

Robots will be autonomous type. It is not allowed remote control except “remote start-stop function”

3. The weight of the robot

The weight of mini sumo robot will be maximum 500gr.

4. Starting the movement

Mini sumo robots; Judge will start both robots at the same time by remote controller and robots should move in 10sec.

5. Terminating the movement

Judge announced the end of round. It is not compulsory to stop the robots by judge’s remote controller at the end of round.

6. The rules for using blades.

- a. Paper test will be applied to the robots by the judges. Robots that have very sharp blades won’t be accepted.
- b. Using the blades should not cause any damages to Dohyo and injury to spectators. Robots which have materials such as craft knives, razor blade etc. won’t be accepted.
- c. Judges will decide whether disqualify the robot which damaging to Dohyo or not.

7. The measures of fire prevention

To prevent the over-current in battery, robots should be equipped with fuse or poly-switch or the blocking by the circuit. Otherwise judges will interfere the robots which are broken or cause dangerous situations.

In case of fire or explosion on robots, judge can stop the match and then judges decide whether the match continue or not. If judges decide to terminate the match, scores of current and remain rounds are given to opponent.

(Movements of Robots)

Article 5: The movements of the robot should be designed to detect the movements of the opponent and respond/attack accordingly. If the movement is suspicious, operation check maybe made by indication of the judges. The check is carried out as the condition that a match terminates without program modification.

(Prohibited items in design and manufacturing of the robots)



Article 6: Prohibitions

1. Any components that may affect the operating frequency or operation of opponents (such as flasher) are prohibited. Infrared signals emitted from the standard optical sensors on the robots will not be evaluated in this context.
2. Using any components that may scratch or cause any damages on the surface of dohyo are prohibited
3. Liquid, powder or gas which is used as a weapon or attack mechanism against the opponent are prohibited
4. Inflammable components should not be installed in the robots.
5. It is not allowed that placing batteries caused to damage Dohyo, other robot or itself.
6. The robot must not include any kind of launching device.
7. The robot must not include any parts that stick the robot to dohyo surface and prevents its movement (such as suckers, glue and so on)

Chapter 5 Game Principles

Article 7: Game Principles

1. In principle, the competition time based on three matches in 3 minutes of each. Team who get two effective points within the competition time will be the winner.
2. If only one single effective point has been got by the end of the competition time, the team that has get this point will be the winner of the competition.
3. In case of equality such as 1-1 or 0-0, the competition will be extended one more round. In extension time, the team who get 1 effective point will be the winner of the competition.
4. Within the match time, if no team has win any round, 1 effective point is given to lighter robot than other according to robot weight and then the winner is determined.
5. Before the match is over, all maintenance is prohibited. (however, under supervising of judge, competitors can interfere only in 30 seconds without leaving match area and getting any technical support from outside. They also cannot change anything on robot in this moment)

Chapter 6 Carry out the Competition

(Safety measurements)

Article 8: Safety measurements

1. For safety, the competitors should wear goggles, gloves and sports shoes during the match. Teams that miss such safety equipments won't be accepted.

(Beginning of the Game)

Article 9: Competitors must have safety equipments such as glasses, shoes etc.

1. Judges will start the match after checking the dohyo and competitors as well. If there are any scratches/dirt in the dohyo, the judges will decide whether the match can continue on the same dohyo or not.
2. The match will begin when placing robots on Dohyo by the instruction of judges.
3. Placement of robots will be determined by judges as side by side or back to back
4. Robots are not allowed to be moved after they have been placed.
5. The game will start when judge presses the remote control and robots move.



(The ending of the game)

Article 10: The ending of the game

1. Game will officially end upon the announcement of judge.
2. Contestants will take their robots from the outside of dohyo by moving only inside restricted competitor area.

(Restart of a match)

Article 11: In the following situations, the match will be suspended and resumed.

1. In case of both robots are stuck facing each other and further movements are not possible. it will be waited in 10 second, then after round restarted by judges.
2. In case of that both robots fall out into the outside of Dohyo simultaneously.
3. If winner cannot be determined after 3 rounds, the judge places the robots in a specific position symetrically and restart 4. round which is last round.

Chapter 7 Points

(Effective point)

Article 12: The winner of round is determined based on the following situations.

1. If the opponent robot is forced out of dohyo and the robot touches outside of dohyo.
2. If the opponent robot falls out of Dohyo by itself and touches outside of Dohyo
3. If the robot stays inactive more than 10 seconds (inactive robot loses the round even if the other robot touches out of Dohyo)
4. If some parts described in Article 14 are falling down
5. If “warning ” was given two times to the opponent.

Chapter 8 Warnings and Penalties

(Warning)

Article 13: A contestant who takes any of the following actions will receive a warning. If a contestant receives two warning, one effective point will be granted to his/her opponent.

1. Any violation of Article 6.
2. If the robot is repositioned once it has been placed in Dohyo.
3. All actions that may be deemed unfair / tricky by judges.

(Violations)

Article 14: If the following situation happens, the opponent will be granted one effective point.

1. If the components (over than 10gr.) were dropped from the robots
2. If the robot doesn't move within 10sec. after starting signal.
3. If there is an application from contestants to terminate the match.

(Loss because of vialotions)



Article 15: A contestant who takes any of the following actions will lose the game because of violation.

1. A contestant doesn't come to the appointed dohyo in 5 minutes.
2. A contestant sabotages the game. For example, by intentionally breaking, damaging or defacing dohyo.
3. A contestant violates Article 4.
4. If robot cannot move as described in Article 5 "the requirements of autonomous robots"
5. If the robot fires and then then it causes the robot broken.

(Disqualifications)

Article 16: A contestant who take any of the following actions will be disqualified and forced to leave the game and will not be on the ranking list.

1. A contestant's robot does not meet the requirements which is stated in Article 6 "specification of the robots" .
2. A contestant doesn't respect the fairplay rules. (For example, using offensive language or assaulting opponents or judges).
3. A contestant injures the opponent or judges deliberately.

Chapter 9 Injuries and Accidents

(Request for suspension/postpone)

Article 17: Request for suspension/postpone

1. When a contestant is injured and the game cannot be continued , a suspension can be requested by the contestant.
2. In the event above , the judges will make necessary arrangements for the game to be resumed immediately.
3. If the arrangements made do not enable match to be resumed, the opponent will be declared as a winner without match.

Chapter 10 Objections

Article 18: Objections to appeal against the decisions of judge will be given in written by using official web address.

Chapter 11 Specifications of robot marking

(placement direction of robot on Dohyo)

Article 19:

- a. Judges decide how to place the robots on Dohyo. Head to head placement does not allowed. (In extention rounds, judges will decide the placements of robots on Dohyo symetrically)

- b. Before the match, Sumo robots should be placed manually at the same time according to rules shown below. It is not allowed to change the position of robots once they were placed on Dohyo.
- c. Robots will be placed back to back on any place in quadrants as shown in Figure 3

(Robot markings)

Article 20: Photos of robots will be taken and the stickers will be pasted on each of them at the first day of competition.

Chapter 12 Others

Article 21: Tournament Committee is authorized for all kinds of modifications about the rules of contest.

Chapter 13 Dohyo Pictures

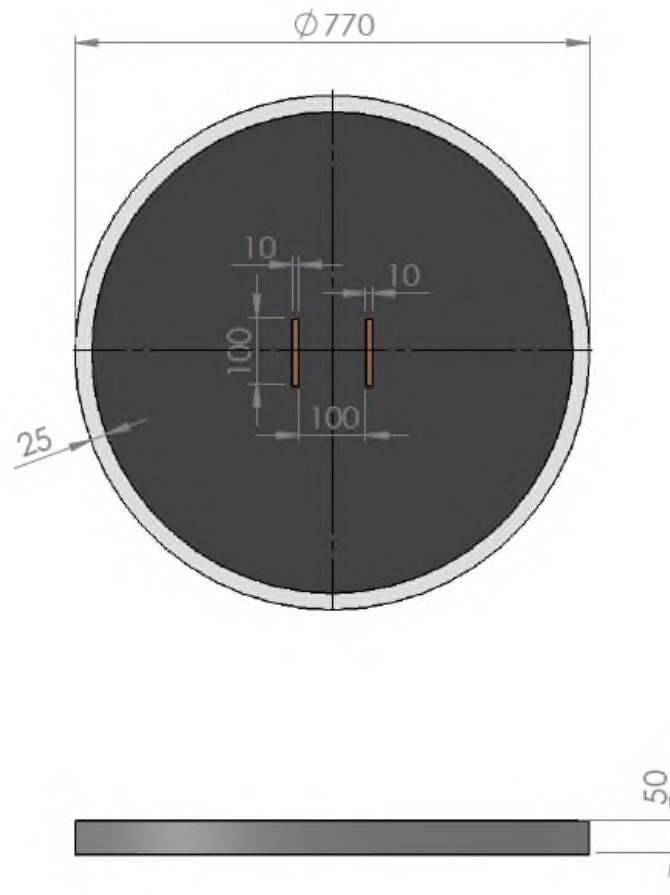

Figure 1 Dimensions of Dohyo for Mini Sumo Robot Competition(mm)

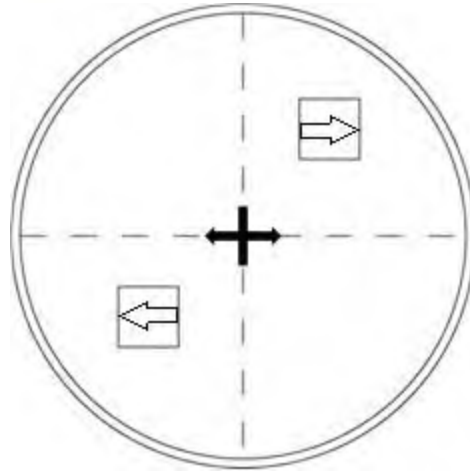

Figure 2 Placement of Mini Sumo Robot on Dohyo

Article 22: Teams will prove Start/stop circuit of mini sumo robots by themselves. No any start/stop module will be given to teams.

START MODULE

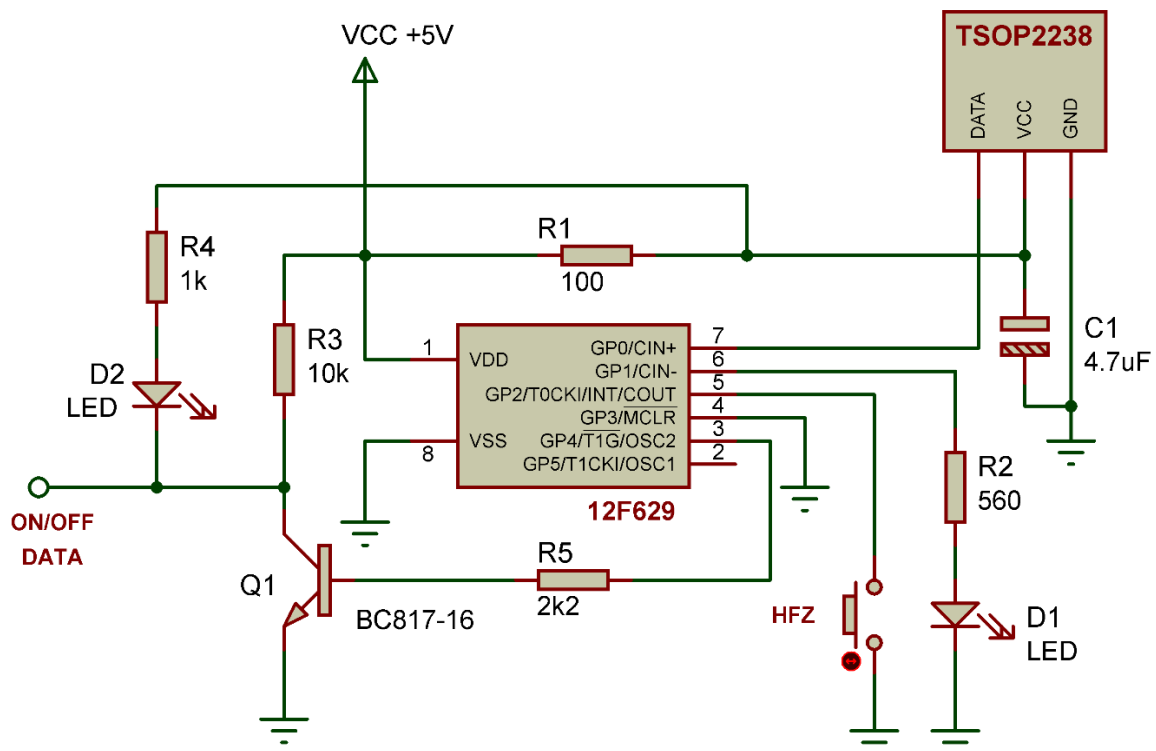

Figure 1: Start Module circuit

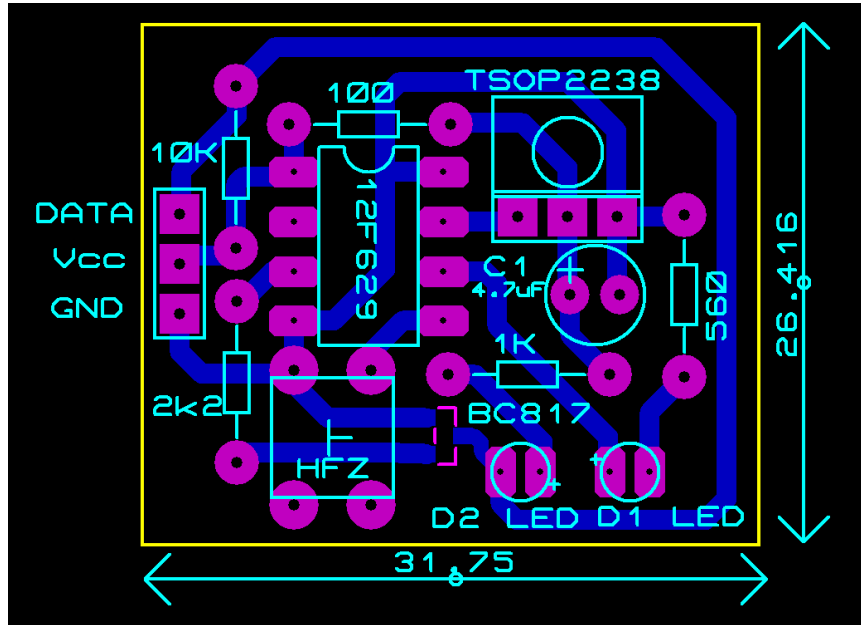

Figure 2: Start Module PCB

START MODULE: HOW TO USE

First of all, which button on transmitter will be used for on/off function on receiver side should be determined. You should push memory button on the receiver and then D1 led turns on permanently. At this time, you should press a button on transmitter two times successively then wait. D1 led will turn off. Now module is ready to use.

To set the output ON, push the button (memorized button on transmitter) one times. D1 led will flash but D2 will turn on permanently. The output voltage drops 0V.

To set the output OFF, push the button (memorized button on transmitter) one times. D1 led will flash but D2 will turn off permanently. The output voltage rises to +5V.

You can use any kind remote controller using “RC5” protocol as a transmitter for this circuit. A special area called “test point” will be reserved for competitors to test their remote modules.

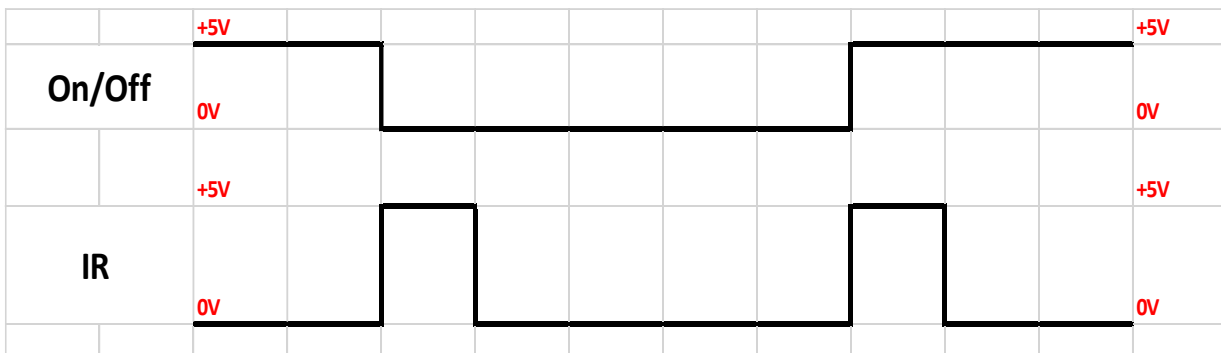

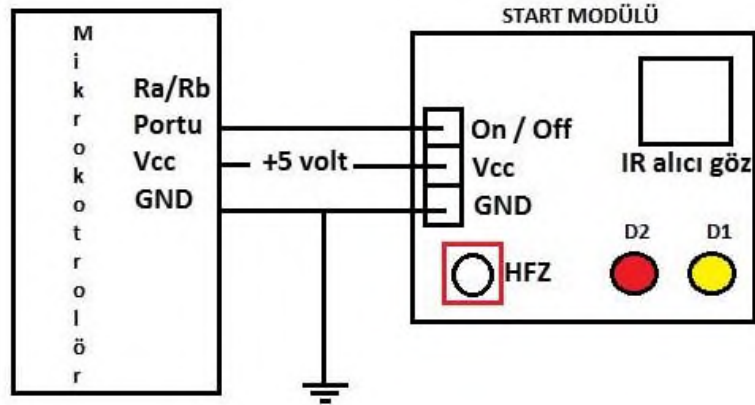

Wiring diagram between MCU and start module